

1 1/2" BORE STAINLESS STEEL CYLINDER



CSN-24-□-□

Single Acting

Mount: Clevis **Standard Stroke Lengths:** 1/2", 1", 1-1/2", 2", 3", 4"
Type: Non-Rotating Rod **Spring Compressed:** 10 lbs. **Spring At Rest:** 4 1/2 lbs.
Options: MB, B, H, V, P6, N For magnetic bumpers add .312

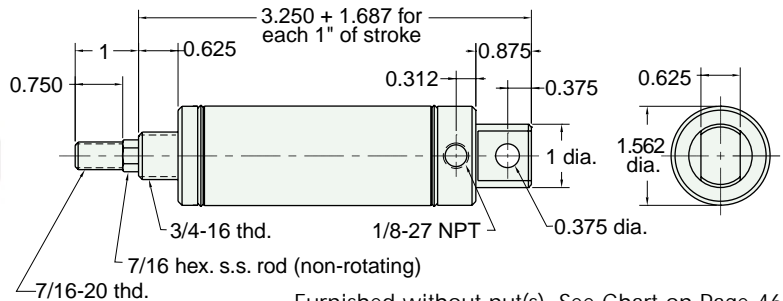

Furnished without nut(s). See Chart on Page 46.

CSR-24-□-□

Single Acting

Mount: Clevis **Standard Stroke Lengths:** 1/2", 1", 1-1/2", 2", 3", 4"
Type: Rotating Rod **Spring Compressed:** 10 lbs. **Spring At Rest:** 4 1/2 lbs.
Options: MB, B, H, V, P6, N For magnetic bumpers add .312

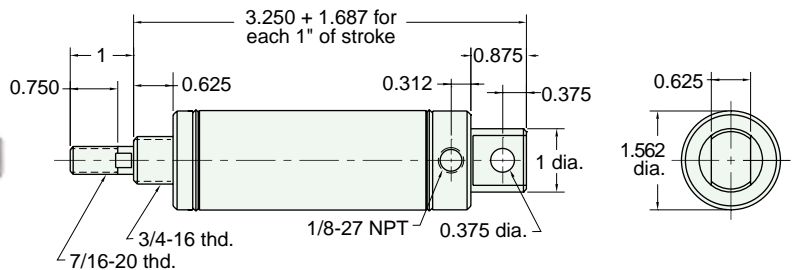

Furnished without nut(s). See Chart on Page 46.

ESN-24-□-□

Single Acting

Mount: End **Standard Stroke Lengths:** 1/2", 1", 1-1/2", 2", 3", 4"
Type: Non-Rotating Rod **Spring Compressed:** 10 lbs. **Spring At Rest:** 4 1/2 lbs.
Options: MB, B, H, V, N For magnetic bumpers add .312

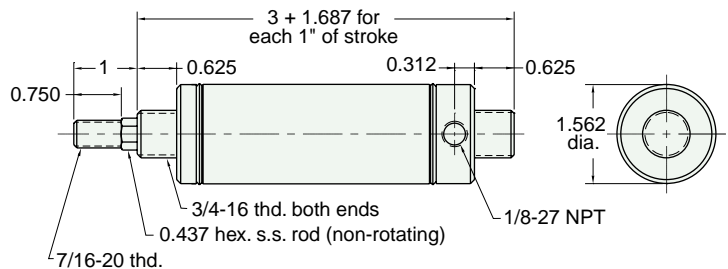

Nuts included, but not shown on drawing

ESR-24-□-□

Single Acting

Mount: End **Standard Stroke Lengths:** 1/2", 1", 1-1/2", 2", 3", 4"
Type: Rotating Rod **Spring Compressed:** 10 lbs. **Spring At Rest:** 4 1/2 lbs.
Options: MB, B, H, V, N For magnetic bumpers add .312

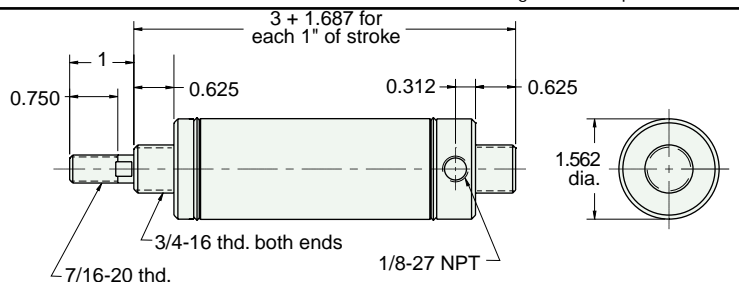

Nut included, but not shown on drawing